

NTA UGC NET

ELECTRONIC SCIENCE

SAMPLE THEORY - *(English Medium)*

- * SPEED CONTROL OF DC MOTORS
- * FIELD FLUX
- * FIELD CONTROL



UGC NET ELECTRONIC SCIENCE

SAMPLE THEORY

SPEED CONTROL OF DC MOTORS
FIELD FLUX
FIELD CONTROL

VPM CLASSES

FOR IIT-JAM, JNU, GATE, NET, NIMCET AND OTHER ENTRANCE EXAMS

Web Site www.vpmclasses.com E-mail-info@vpmclasses.com

Speed control of DC motors:-

The term 'speed control' stands for intentional speed variation, carried out manually or automatically. Natural speed change due to load, is not included in the term 'speed control'.

DC. motors are most suitable for wide range speed control and are, therefore, indispensable for many adjustable speed drives .

The speed of a d.c. motor is given by and it is re-written here fore convenience, i.e.

$$\omega_n = \frac{V_t - I_a r_a}{K_a \phi} \quad \dots (1)$$

where armature constant $K_a = \frac{PZ}{2 \pi a}$ and ϕ is the field flux per pole.

It follows from Eq. (1) that for a d.c. motor, there are basically three methods of speed control and these are :

- (i) Variation of resistance in the armature circuit.
- (ii) Variation of the field flux, and
- (iii) Variation of the armature terminal voltage.

Before describing these methods, it is preferable to define the terms base speed, speed regulation, speed range, constant power drive and constant torque drive.

Base Speed. It is defined as the speed at which a motor runs at rated armature voltage and rated field current. Base speed is equal to the rated speed or nameplate speed of the motor.

Speed regulation. If the speed-change from no load to full load is $\Delta \omega_m$ then speed regulation is defined as the ratio of $\Delta \omega_m$ to rated speed (or base speed) ω_m .

Per cent speed regulation
$$= \frac{\Delta \omega_m}{\omega_m} \times 100 \quad \dots (2)$$

Speed range. It is defined as the ratio of the maximum allowable speed to minimum allowable speed of the motor. When the speed range of a motor is specified, it must be mentioned whether this speed range is at no-load, full load or a fraction of full load.

Constant power drive. If the motor shaft power (shall torque \times speed) remains constant over a given speed range, the system is called a constant power drive.

Note that in constant power drive, higher torques are available at lower speeds and lower torque at higher speeds. The motor size is always decided by the highest torque requirement at the lowest speed.

Constant torque drive. If the motor shaft torque remains constant over a given speed range, the system is called a constant torque drive. Note that in constant torque drive, shaft power varies as the speed varies.

- a. Methods of speed control. There are three methods of speed control: –
- Speed control by varying armature circuit
 - Speed control by varying the field flux.
 - Speed control by varying armature terminal voltage.
- i Speed control by varying armature circuit :-

Speed control by varying the armature-circuit resistance. This method is also called armature-circuit-resistance control method. In this method, an external resistance is inserted in series with the armature circuit to obtain speeds below the base speed only.

i. Shunt motor. The scheme of connections of a shunt motor is illustrated in Fig where resistor R_g , called a controller, is put in series with the armature circuit. Note the difference between a starter and a controller, the former is designed to carry current only for a short time, whereas a controller can carry current for an indefinite time, without getting excessively hot.

When R_g is not present, then the armature current I_{a1} , from Eq. is

$$I_{a1} = \frac{V - K_a \phi \omega_m}{r_a}$$

When R_g is inserted in the armature circuit and if it is assumed that there is no change in speed for the time being, then

$$I_{a1} = \frac{V - K_a \phi \omega_m}{r_a + R_g} = I_{a1} \frac{r_a}{r_a + R_g}$$

In a shunt motor, field flux remains unchanged, therefore, with the reduction of armature current to I_{a1}' , electromagnetic torque $T_e (= K_a I_a)$ decreases from $K_a I_{a1}$ to $K_a I_{a1}'$. Since T_e has become less than constant load torque, the speed decreases, counter (or back) e.m.f. also decreases. As a result of it, armature

current $I_a = \frac{V - \text{counter e.m.f.}}{r_a}$ increases till it becomes

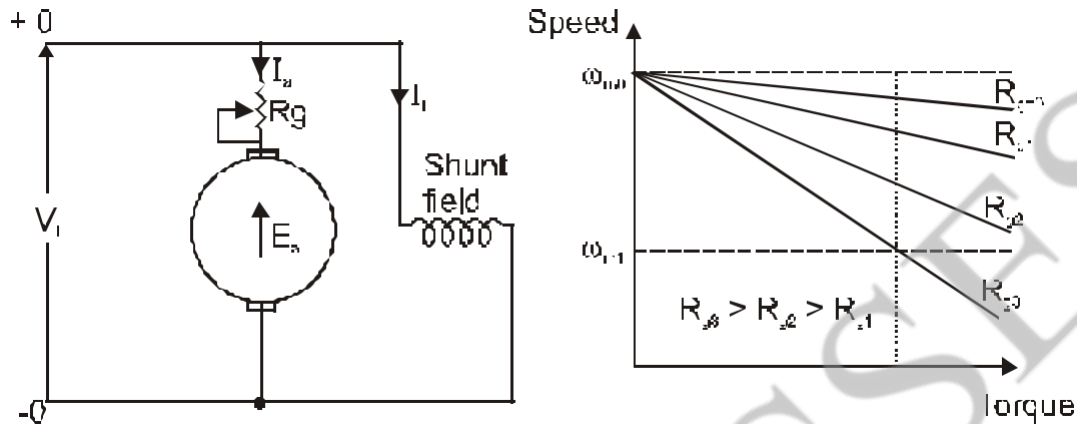

Fig.1 Shunt motor speed control by varying the armature circuit resistance (a) Schematic circuits diagram and (b) speed-torque characteristics.
equal to its initial value I_{a1} , so that the initial electromagnetic torque $K_a I_{a1}$ is developed again.

$$\text{From Eq. } \omega_{m1} = \frac{V_t - I_{a1} r_a}{K_a \phi} = \frac{E_{a1}}{K_a \phi}$$

When new steady state condition is reached, with R_g in the armature circuit, then

$$\omega_{m2} = \frac{V_t - I_{a1} (r_a + R_g)}{K_a \phi} = \frac{E_{a2}}{K_a \phi}$$

$$\frac{\omega_{m2}}{\omega_{m1}} = \frac{n_2}{n_1} = \frac{E_{a2}}{E_{a1}} = \frac{V_t - I_{a1} (r_a + R_g)}{V_t - I_{a1} r_a} \quad \dots (3)$$

Equation (3) shows that ω_{m2} is less than ω_{m1} .

Thus, for this type of speed control and with a constant load torque, it can be concluded as follows .

(a) The armature current drawn from the supply remains constant. Also the power delivered from the supply mains to the motor does not change and remains constant at $P_1 = V_t I_{a1}$, whether R_g is in the armature circuit or not.

(b) Power delivered to load is $P_2 = E_{a2} I_{a1} = [V_t - I_{a1} (r_a + R_g)] I_{a1}$ or $P_2 = (\text{constant load torque}) \times \omega_{m2}$. It is thus seen that the power P_2 delivered to load decreases in proportion to the decrease in speed.

The efficiency of the method of speed control is

$$\eta = \frac{P}{P_1} = \frac{V_t}{V_{t a1}} = \frac{V_t - I_{a1}(r_a + R_g)}{V_t} = 1 - \frac{r_a + R_g}{V_t} I_{a1}$$

If R_g is increased to obtain lower operating speeds, the motor efficiency is lowered and this results in higher operational costs .

- a. Advantage.** The principle advantage of this method speeds below base speed down to creeping speeds of only a few r.p.m., are easily obtainable. But, because of considerable waste of energy at reduced speeds; this method is economically viable where only short time or intermittent slow down are required.
- b. Disadvantage.** The disadvantages of this method are : (i) lower efficiency and higher operational costs at reduced speeds as proved above and (ii) poor speed regulation with fixed controller resistance R_g in the armature circuit. For example, for a controller resistance equal to R_{g3} the speed is w_{m1} at a certain load torque and for the same R_{g3} , the speed becomes almost w_{m0} at no load.

ii. **Series motor:**

In case of series motor, if wide range of speed control is required, it is usually carried out by this method.

Fig illustrates the schematic diagram of a d.c. series motor for its speed control by varying the armature circuit resistance.

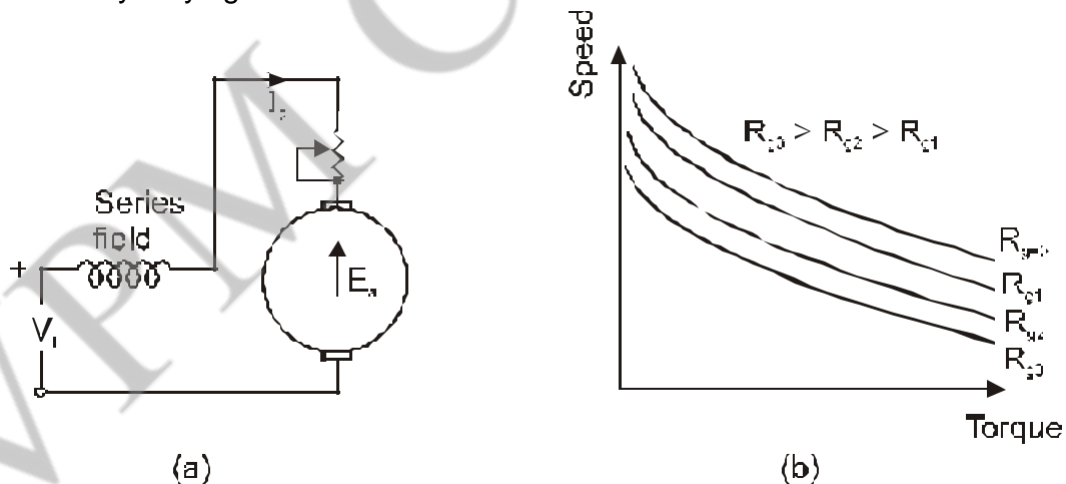

Fig.2 Series motor speed control by varying the armature circuit resistance

(a) Schematic circuit diagram and (b) speed-torque characteristics.

Before the introduction of resistor R_g ,

$$V_t = K_a \phi_{m1} + I_{a1} (r_a + r_s)$$

If saturation is neglected, then field flux is proportional to the armature current. Let = $C I_a$ so that

$$\phi_{m1} = C I_{a1}$$

$$V_t = [K_a C \phi_{m1} + (r_a + r_s)] I_{a1} = [L \phi_{m1} + (r_a + r_s)] I_{a1}$$

$$I_{a1} \text{ where } K = \frac{K_a C}{\phi_{m1}}$$

$$\omega_{m1} = \frac{V - I_{a1} (r_a + r_s)}{K I_{a1}}$$

... (4)

After the resistor R_g is inserted in series with the armature circuit as shown in Fig.2(a)

$$V_t = [K_a C \phi_{m2} + (r_a + r_s + R_g)] I_{a2}$$

For constant load torque, $K_a \phi_{m1} I_{a1} = K_a \phi_{m2} I_{a2}$

$$\text{or } K_a C I_{a1}^2 = K_a C I_{a2}^2$$

$$\text{or } I_{a1} = I_{a2}$$

$$V_t = [K_a C \phi_{m2} + (r_a + r_s + R_g)] I_{a1}$$

$$\text{and } \omega_{m2} = \frac{V_t - I_{a1} (r_a + r_s + R_g)}{K I_{a1}}$$

... (5)

From eqs . (4) and (5)

$$\omega_{m2} = \frac{V - I_{a1} (r_a + r_s + R_g)}{K I_{a1}}$$

$$\frac{\omega_{m1}}{\omega_{m2}} = \frac{n_1 V_t - I_{a1} (r_a + r_s)}{V - I_{a1} (r_a + r_s + R_g)}$$

$$\frac{E_{a2}}{E_{a1}}$$

.... (6)

Eq. (6) show that ω_{m2} is less than ω_{m1} .

Poor speed regulation is not of much importance in case of series motors . This method of speed control is employed chiefly for series motors driving cranes, hoists, train etc. The resistors employed for limiting the armature starting current, may be used for speed control purposes also.

In order to fully utilize the motor capacity at all speeds, the armature current is kept equal to the allowable armature current, i.e. the rated armature current. For shunt motor, the field flux is obviously constant. For series motor, the field flux is also constant, because it is produced by armature current which is maintained equal to its

rated value. Since field flux remains constant in both types of motors, armature-circuit-resistance control method is usually referred to as a constant torque [(constant field flux) (rated armature current)] drive method.

Shunted-armature method. Speed control by armature-circuit resistance control can be carried out easily, but it suffers from poor speed regulation. This disadvantage can be overcome by shunted-armature method, which is a modification of the armature-circuit resistance control method. In this modified method, external resistances are inserted both in series and in parallel with the armature, as shown in **Fig-3(a)** for a shunt motor and in **Fig-3(b)** for a series motor. In effect, combination of R_1 and R_2 acts as a potential divider and the voltage across R_2 is applied to the armature.

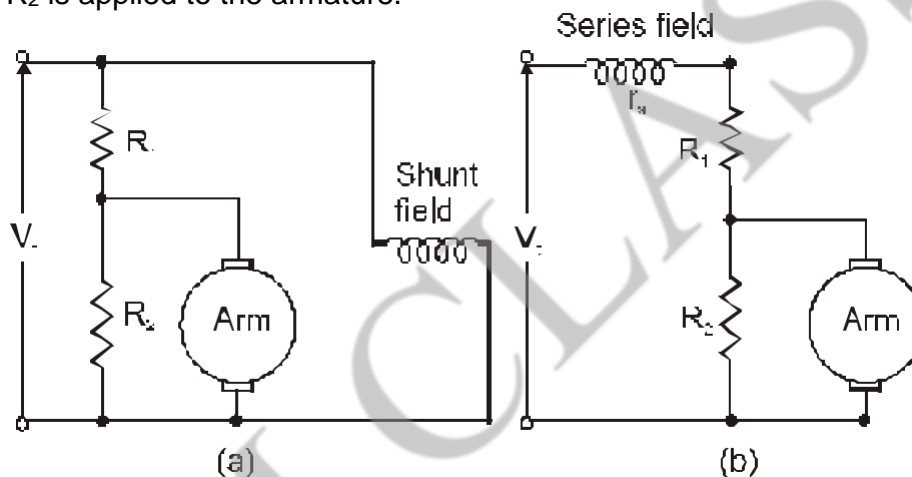

Fig-3 Shunted armature method of speed control **(a)** for shunt motor and **(b)** for series motor.

For a d.c. shunt motor, shunt field current is unaffected by R_1 and R_2 . Applying Thevenin's theorem at the armature terminals, the Thevenin's equivalent circuit for Fig-3(a) is as illustrated in Fig-3(b), where the shunt field winding is not shown. From this equivalent circuit,

$$E_a = K_a \omega_m = V_t \frac{R_2}{R_1 + R_2} - I_a \times \frac{R_1 R_2}{R_1 + R_2} - I_a r_a$$

$$\omega_m = \frac{1}{K_{af}} [AV_t - AR_1 I_a - I_a r_a]$$

$$= \frac{1}{K_{af}} AV_t - I_a \left(\frac{AR_1}{K_{af}} + r_a \right) \quad \dots (7)$$

where $A = \frac{R_2}{R_1 + R_2}$.

Electromagnetic torque

$$T_e = K_a I_a$$

$$\omega_m = \frac{1}{K_a \phi} AV - \frac{T_e (AR_1 + r_a)}{K_a \phi}$$

By varying both R_1 and R_2 and therefore A , speed ω_m can be controlled.

For a series motor, Thevenin's equivalent circuit looking from the armature terminals is as shown in Fig. From this equivalent circuit,

$$E_a = K_a \omega_m = V_t B - (r_s + R_1) I_a - r_a I_a$$

or $\omega_m = \frac{1}{K_a \phi} [V_t B - (r_s + R_1) I_a - r_a I_a]$

or $\omega_m = \frac{1}{K_a \phi} [V_t B - I_a \{(r_s + R_1) B + r_a\}] \dots (8)$

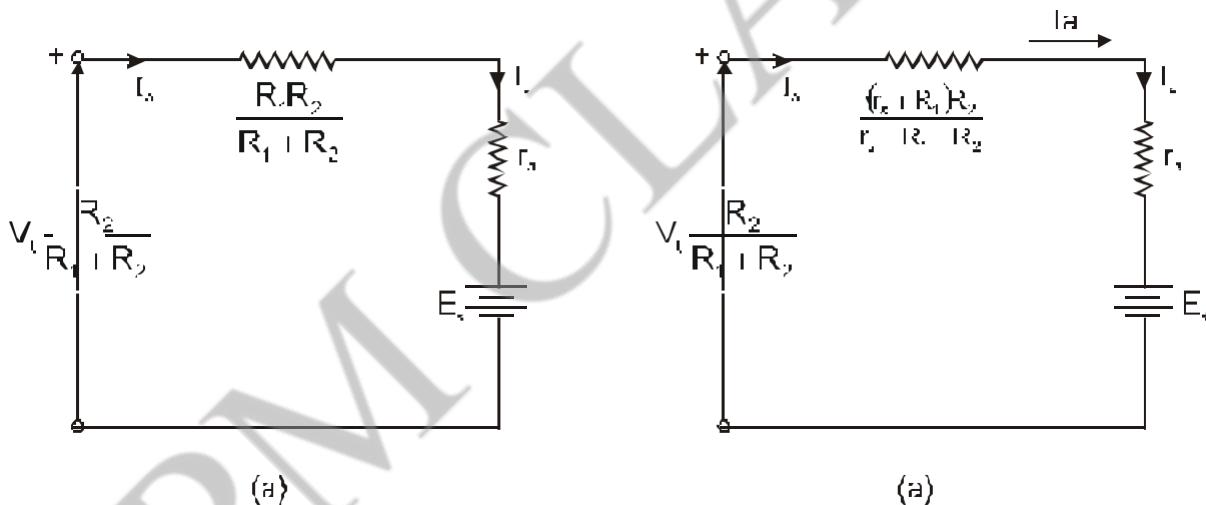

Fig-4 Thevenin's equivalent circuits (a) for Fig (a) and (b) for Fig (b).

where $B = \frac{R_2}{r_s + R_1 + R_2}$

By varying both R_1 and R_2 and therefore B , the speed control can be carried out as is evident from Eq. (8).

By Shunted-armature method, no-load speed of a dc series motor is not dangerously high ; it can be adjusted to any desired value by an appropriate choice of resistors R_1 and R_2 . Further this method of speed control gives better speed regulation than that obtained by the conventional method of adding external resistance in series with the armature circuit.

Speed control by varying the field flux. This method of speed control, also called field-weakening method or field-current control method, gives speeds above the base speed only.

Shunt motor. The arrangement of connections is showing in Fig. The field flux and hence the speed of a shunt motor, can be controlled easily by varying the field regulating resistance. This is one of the simplest and economical methods and is, therefore, used extensively in modern electric drives .

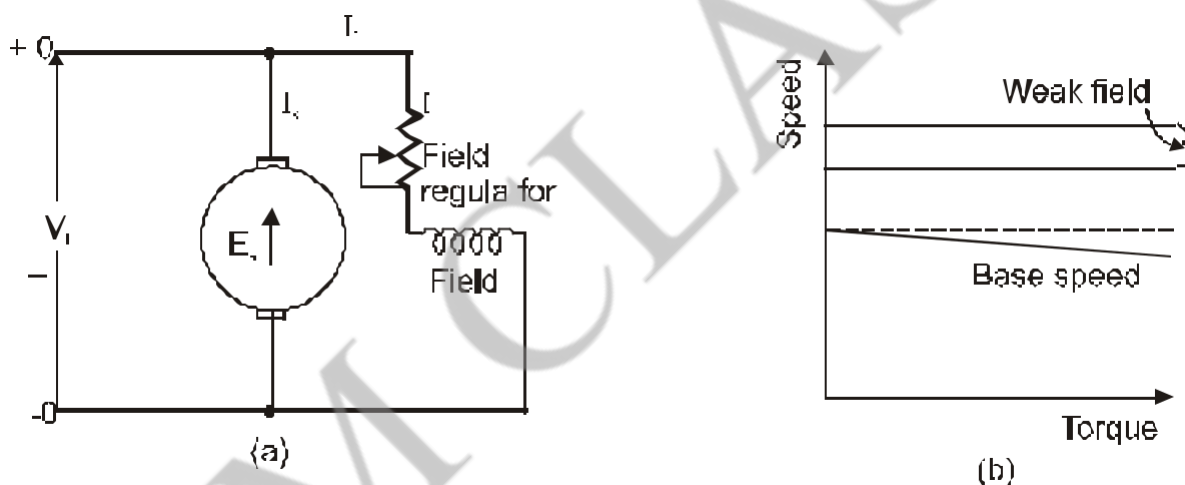

Fig.5 Shunt motor speed control by varying

Under steady running conditions, if field circuit resistance is increased, the field current I_f and the field flux are reduced. Since the rotor speed can't change suddenly due to its inertia, a decrease in field flux causes a reduction of counter emf. As a result of it, more current flows through the armature

$[I_a = (V_t - \text{counter e.m.f.})/r_a]$. The percentage increase in I_a is much more than the percentage decrease in the field flux. In view of this, the electromagnetic torque is increased and this being more than the load torque, the motor gets accelerated.

With this, the counter e.m.f. rises and I_a starts decreasing till electromagnetic torque becomes equal to the constant load torque.

If armature current is I_{a1} for flux ϕ_1 , and I_{a2} when the flux is changed to ϕ_2 , then for a constant load torque,

$$I_{a1} = \frac{T_e (= T_L)}{K_a \phi_1}$$

$$\omega_{m1} = \frac{V_t - I_{a1} r_a}{K_a \phi_1}$$

$$I_{a2} = \frac{T_e (= T_L)}{K_a \phi_2}$$

$$\omega_{m2} = \frac{V_t - I_{a2} r_a}{K_a \phi_2}$$

The above phenomenon describing the changes in speed and armature current as the field flux is varied.

a. Disadvantages : The disadvantages of this method are as follows:

- Top speeds are obtained with very weak field. This weak field at top speeds causes the armature current to increase for the development of certain load torque. With increased armature current associated with weak main field, the resultant field waveform is badly distorted.
- The armature may get overheated at high speeds because the increased armature current results in more ohmic losses whereas cooling by ventilation does not improve proportionally.
- If the field flux is weakened considerably, the speed becomes very high and due to these changes, the motor operation may become unstable.

Series motor. The field flux and, therefore, the speed of a series motor can be varied (a) by placing a resistor, called a diverter, in parallel with the series field winding as shown in Fig. a(b) by tapping the series field winding as shown in (b), and (c) by changing the field coil connections from series to parallel,

(a) Diverter field control. When the diverter resistance is varied, the current in the series field winding is changed, **Fig-6 (a)** and there is, therefore, a corresponding change in field flux and the speed.

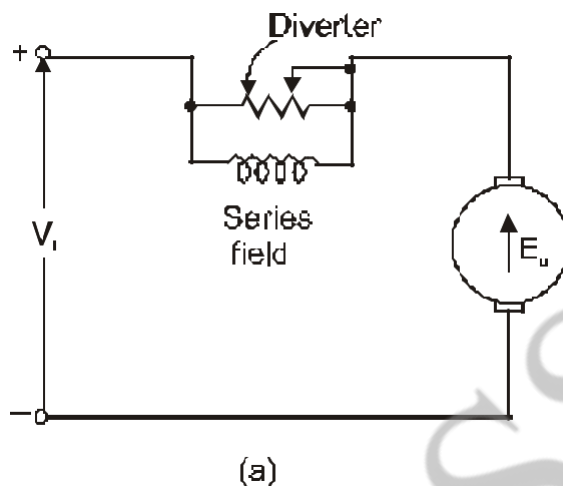

Fig- 6 (a) Series motor speed control (a) by a diverter.

(b) Tapped-field control. When the field winding is tapped, **Fig-6(b)**, the number of series field turns is changed and, therefore, the series field m .m .f. and the speed are changed.

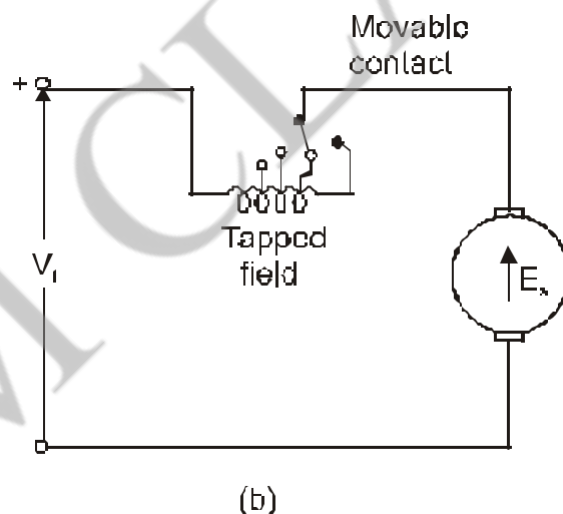

Fig-6(b) Series motor speed control (a) by tapped field.

If the series motor is to work under violently varying loads, then the diverter resistance should be highly inductive. For example, when the series motor is used for traction purposes, the current collector may lose contact with the overhead wire. After this, the motor continues running due to inertia, but the current and, therefore, the series field flux may collapse. After a short while, when the contact with overhead wire is re-established, the entire current may pass through the resistive

For a constant load torque, a decrease in field flux, gives increased I_a and increased speed. Thus power input $V_t I_a$ and power output (= constant load torque \times speed) increase and, therefore, efficiency remains almost unchanged.

For both shunt and series motor control, the counter e.m.f. E_a remains substantially constant. Because a decrease in field flux is compensated by a corresponding increase in speed. If the armature current I_a is kept equal to the motor rated (or nameplate) current for its full utility, the power output $I_a E_a$ remains approximately constant and for this reason, field-flux speed-control method may be called a constant power drive method.

Since $E_a I_a$ remains approximately constant, the maximum torque is obtained when the d.c. Motor runs at the lowest speed. In view of this, field-flux control method is suitable to drives requiring large torques at low speeds. In case the field-flux control method is used to drive a load requiring constant torque over the entire speed range, then motor rating and size are decided by the product of constant torque and the highest possible speed. Obviously, such a motor at low operating speeds will be underutilized.

Speed control by varying the armature terminal voltage. Reference to Equation shows that if the armature terminal voltage V_t is varied. Counter e.m.f. ($V_t - I_a R_a$) changes almost proportionally and for a constant-flux motor (e.g., a d.c. shunt motor), the speed changes approximately in voltage. So, for driving a dc motor, ac must be converted to dc and then only fed to dc motor armature for its speed control. DC motor speed control by varying the armature terminal voltage is obtained by (a) Ward-Leonard system (b) controlled rectifiers and (c) series-parallel armature control.

(a) Ward-Leonard system. The schematic diagram of this system is illustrated in Fig. In this figure, M is the separately excited d.c. Motor whose speed is to be controlled and G is the separately excited generator driven by a three-phase driving motor (usually an induction motor). The combination of a.c. driving motor and the d.c. Generator is called motor-generator set and it converts a.c. into d.c. Which is fed to the main motor M. If no supply is available, the three phase motor can be replaced by some prime mover.

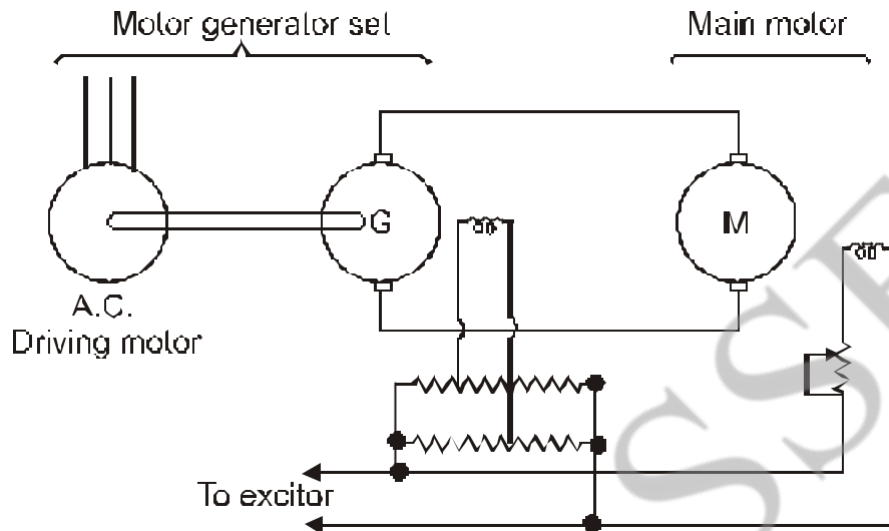

Fig-7 Schematic diagram of Ward-Leonard system of speed control

For starting motor M, its field circuit is first energized and then the generator output voltage is adjusted to a low value by decreasing its field excitation. This is done in order to limit the starting current to a safe value but it should be ensured at the same time that enough starting torque is produced to accelerate the motor and the load. In view of this, no starting rheostats are necessary and therefore, considerable amount of energy is saved during starting. A change in the generator field current varies the voltage applied to the motor armature and therefore, the motor speed is changed. Thus the motor speed control is obtained merely by changing the generator field current.

In order to achieve wider speed control range, speeds below base speed are obtained by voltage control and above base speed, by field flux control. For better utility of motor M, its current I_a is maintained equal to its rated current during its speed control.

Speeds, from the lowest possible speed up to base speed, are obtained by increasing the generator output voltage, with constant motor field flux. Since the speed control is carried out with rated current I_a and with constant motor field flux, a constant torque ($\propto \phi I_a$) up to base speed is obtained.

Power (= torque \times speed) increases in proportion to speed. Thus constant torque and variable power drive is obtained up to base speed, with armature-terminal voltage control method as shown in **Fig 7**.

Speeds above base speed are obtained by decreasing the motor field flux with constant generator voltage. As before, the armature current I_a is kept equal to its rated value. Under these conditions, V or E remains constant and the

I_a I_a

electromagnetic torque proportional to I_a decreases as the field flux is decreased. Thus, weakening of the motor field flux results in constant power variable torque drive above base speed, **Fig - 8**

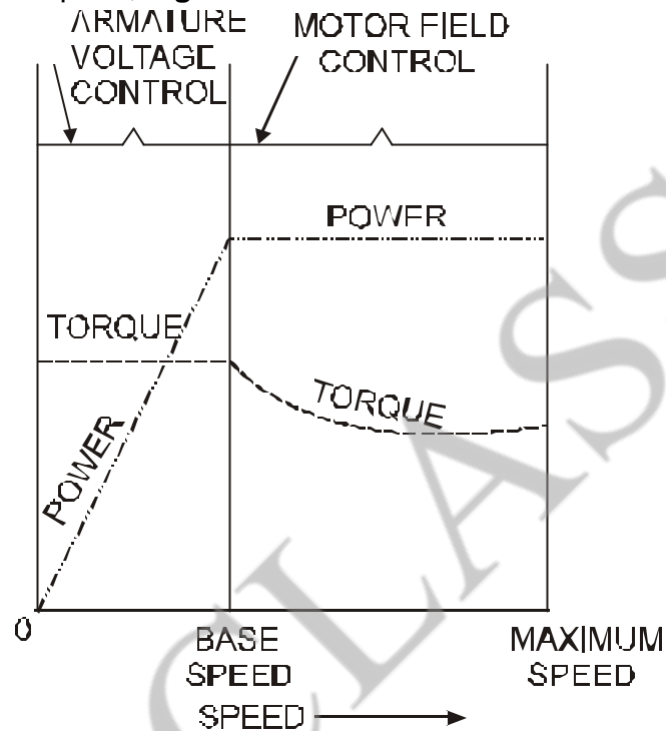

Fig : 8 Torque-speed and power-speed characteristics for Ward-Leonard system of speed control

The speed range with armature voltage control exclusively is 10 : 1, the lowest speed being limited mainly by the residual magnetism of the generator. The speed range with motor field control alone, is 3 : 1 to 4 : 1, the mature heating and unstable operation. When both types of speed controls are employed, the overall speed range is 40 : 1.

Speed range can still be broadened to, say 200 : 1 by the use of amplidynes incorporating closed-loop system .

Breaking of motor M may be carried out by decreasing the generator excitation so that its emf is less than the counter emf of motor M. Under these conditions, M begins to work momentarily as a generator, G as a motor and a.c. Driving machine as a generator. Consequently the kinetic energy of M and its load is returned to the supply mains and braking action on main motor M takes place.

Advantage: The advantages of Ward-Leonard system of speed control are as follows :

- (i) The main advantage of this system is its simplicity, wide range and smooth speed control. Consequently Ward-Leonard system in its original or modified form, is used extensively in rolling mills, colliery winders etc.
- (ii) With armature reaction ignored, the decrease in speed from no load to rated load, is mainly due to the resistance drops in both the generator armature and motor armature. The speed regulation is, therefore, quite good.
- (iii) The direction of main motor rotation can be changed merely by reversing the generator field current.
- (iv) Speed control is carried out through the field circuits of generator and motor. Since these field circuits are low-power circuits, the control apparatus is not costly.
- (v) The efficiency at low speeds, is higher than that obtained by other methods of speed control.

Disadvantage : The only disadvantage of this method is its higher initial cost, because three machines having rating equal to the full load output, are required. **b.**

Speed control with controlled rectifiers: Controlled rectifier d.c. supply can be used in place of motor-generator set of Ward-Leonard system . Now-a-days the silicon controlled rectifiers (or thyristors) have made the SCR-d.c. motor scheme much more economical and its other advantages are less floor space, higher efficiency and quicker control of the output voltage.

Single-phase controlled rectifiers using thyristors are used for the speed control of dc motors below base speed. These are suitable up to about 15 kW rating.

For a single-phase full converter the speed is given by

$$w_m = \frac{2V_m \cos a}{K_a T} - \frac{r_a}{(K_a)^2} \times T_e \quad \dots (9)$$

where V_m = maximum value of 1-phase source voltage
and a = firing-angle delay.

There is usually a small voltage drop in conducting thyristors . If this voltage drop is taken as constant and equal to v_r , then Eq. (9) becomes,

$$w_m = \frac{2V_m \cos a - v_r}{K_a T} - \frac{r_a}{(K_a)^2} \times T_e \quad \dots (10)$$

For dc motor ratings above 15 kW, 3-phas controlled rectifiers using thyristors are used.

The speed in case of 3-phase full converter is given by

$$w_m = \frac{2V_m \ell \cos a - v_r}{K_a \times f} - \frac{r_a}{(K_a f)^2} \times T_e \quad \dots (11)$$

It is seen from Equation (9) to (11) that by varying the firing angle delay a , the motor speed can be controlled. For detailed analysis of single-phase and 3-phase full converters or other types of controlled converters, the relevant literature may be consulted.

The use of single-phase and three-phase controlled converters has made possible the precise speed control of dc motors and has opened up new vistas for their widespread applications in industry.

(c) Series-parallel armature control. This method of armature voltage control requires two identical dc motors coupled together mechanically to a common load. It is usual to employ this method for dc series motors, though it can be used for dc shunt and compound motors .

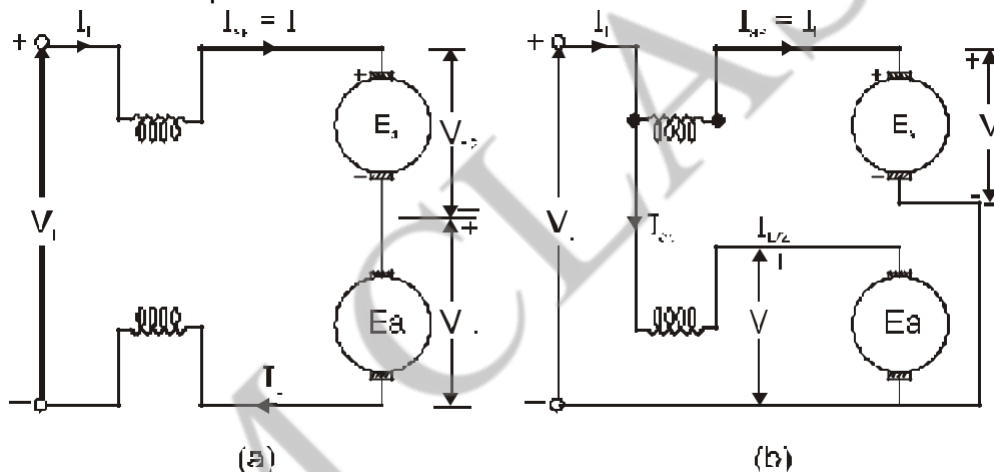

Fig-9 Series -parallel speed control of two dc series motors (a) armature in series and (b) armatures in parallel.

In Fig 9 the connection for series -parallel control of two identical dc motors are shown. When the armatures are in series as in Fig 7(a), the voltage across each armature is $E_{as} = \frac{V_t}{2}$ and the field flux f is established by current $I_{as} = I_L$. This gives motor counter emf ($= K$) as $E_{as} = \frac{V_t}{2} = K I_{Ls} w_s$, where w_s is the motor speed when motors are connected in series and flux because magnetic saturation is neglected. Subscript s stands for series connection.

When the armatures are in parallel as Shown in Fig-7(b) , voltage across each $I_{ap} = \frac{I_L}{2}$. This gives motor counter e.m.f. $E_{ap} = V = K \times \frac{I_L}{2} \times w$ where w is the motor speed when motors are in parallel. Subscript p stands for parallel.

$$\frac{E_{ap}}{E_{as}} = \frac{V}{V/2} = \frac{K \times \frac{I_L}{2} \times w_p}{K \times I_L \times w_s} = \frac{w_p}{2 w_s} \quad \text{or} \quad \frac{w}{w_s} = 4.$$

Electromagnetic torque, $T_e = K_a f I_a$ or $T_e = C I_a^2$ ($\because f \propto I_a$)

When in series, $T_{es} = K I_L^2$ because $I_{as} = I_L$

When in parallel, $T_{ep} = K \frac{I_L^2}{2} = K \times \frac{I^2}{4}$ because $I_{ap} = \frac{I}{2}$

$$\frac{T_{ep}}{T_{es}} = \frac{K \times \frac{I_L^2}{4}}{K I_L^2} = \frac{1}{4}$$

This shows that for the conditions specified in **Fig 9** the ratio of speeds with motors in parallel to that motor in series is 4. The ratio of torques with motors in parallel to that when in series is $\frac{1}{4}$. For constant power input VtI_L from dc source, **Fig-9** offers

constant power drive. It is seen from above that series -parallel armature control method offers only two discrete speeds . This method is commonly employed for the speed control of dc series traction motors .